

PRODUCT NOTE

# EC Titanium™

## Beyond EC efficiency & performance

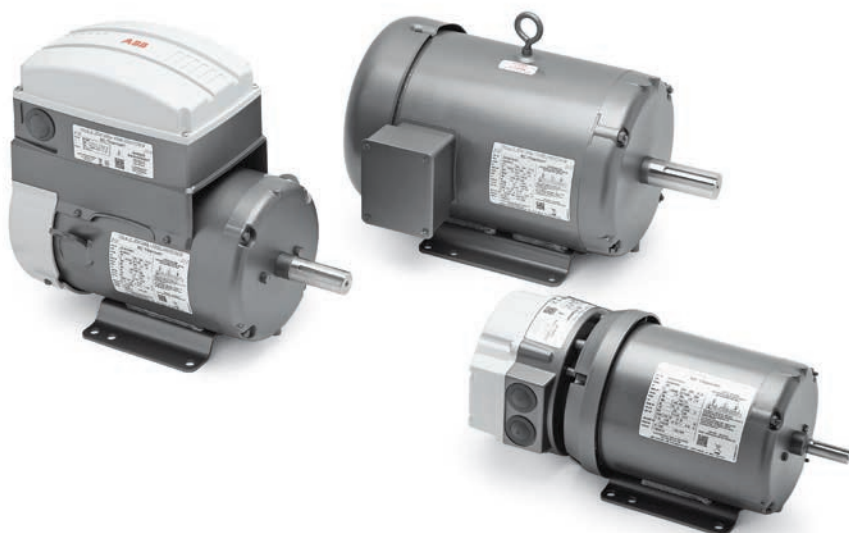

EC Titanium motors are a highly efficient integrated motor drive that combines synchronous reluctance and permanent magnet technologies for a sustainable, wirelessly connected solution that improves your bottom line.

### BALDOR • RELIANCE



**IE5 Efficiency – Stay ahead of the curve**

High total system efficiency at full and partial load



**Minimizing your environmental impact**

Sustainable non-rare earth magnet material

IE5 efficiency – low energy use



**Together as one – Cut the cord**

Integrated motor & drive eliminates expensive wiring and installation time

Reduce personnel risks and hazards of accessing difficult to reach work areas



**Fan & pump control**

Specifically designed for variable speed/torque applications



**Plug and play**

Pre-programmed motor and drive designed to run out of the box

Tune and control flexibility – Keypad, PC or mobile tools for easy Start-up and Bluetooth communication for easy configuration and ABB Ability™ data



**Reliable & low noise**

Extremely low starting current and less cogging reduces mechanical stress, increases reliability and produces ultra-quiet operation.



**Power density**

Higher ratings per frame size than traditional motor designs

Reduces cost and saves valuable space

## Ordering information

### EC Titanium product ordering

A EC Titanium stock assembly consists of the standard rolled steel motor with a selection of a (M) motor only, or either a (T) top mount or (A) axial mount motor drive package and defined by voltage and horsepower at 1800 RPM base speed. Custom configurations are available and can be selected from the part number definition table.

Product series	Frame	Product code	Variant code
<b>ECS</b>	<b>101</b>	<b>M 1 H 10 F F 4</b>	<b>+</b>
		1 2 3 4 5 6 7 8	9

Product series	
ECS	EC Titanium

Frame	Description
100	Rolled steel motor frame, plastic fan and drive cover, bluetooth drive, for indoor use
101	Rolled steel motor frame, aluminum fan and drive cover, non-Bluetooth drive, for indoor use/outdoor/and Plenum use, includes (M) motor only

Position 1	Version
M	Motor only
T	Top mount drive
A	Axial mount drive

Position 2	Voltage
0	230V / 460V 3-phase
1	115V 1-phase
2	230V 3-phase
3	380 – 400V 3-phase
4	460V 3-phase
8	230V 1-phase

Position 3	Power type
H	Horsepower

Position 4, 5	Power rating (HP)
1	1
2	2
3	3
5	5
7	7.5
10	10
15	15
20	20

Position 6	NEMA frame
D	140
E	180
F	210

Position 7	Mounting
F	Foot mount
B	C-Face foot
C	C-Face footless
J	56J stainless threaded shaft
S	Square flange pump mount
D	D-flange
M	JM pump shaft and face
P	JP pump close coupled

Position 8	Base speed
2	3600
4	1800
6	1200
8	900

Position 9	Variants
+	“+” designates minor construction variation(s) (e.g. paint color, shaft length, etc.) that do not affect the performance safety of the product

# Technical data

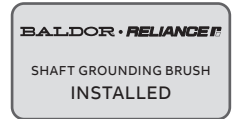

**IP54**

## Drive specification

Voltage & power requirements:	110V - 115Vac (+/- 10%) - 1-phase
	200V - 240Vac (+/- 10%) - 1-phase
	200V - 240Vac (+/- 10%) - 3-phase
	380V - 480Vac (+/- 10%) - 3-phase
Input frequency:	50/60 Hz
Overload capacity:	150% for 1 minute (most models)
Switching frequency:	4kHz, 8Khz, 12kHz, 16kHz, 24kHz, 32kHz
NEMA frames:	140, 180 & 210
Mounting:	Foot, C-Face Foot, C-Face Footless
Analog references:	0-10Vdc, 0-20mAdc, 4-20mAdc
Digital inputs:	24Vdc - (1 = 8 - 30Vdc; 0 = 0 - 4Vdc)
Input configurations:	2 Fixed DI's; 2 Configurable (AI or DI)
Output relay:	No contact; 250Vac, 6A / 30Vdc, 5A
Standards & certifications:	UL 580C, cUL 580C

## Environmental

Enclosure	TEFC/IP54 Motor with UL Type 12/IP54 Drive
Operating temperature	-10 to 50°C (de-rate output 2% per °C above 40 °C)
Storage temperature	-40 to 70°C
Relative humidity	0 95% (non-condensing)
Vibration (operating)	1 G Peak at 20 Hz
Vibration (non-operating)	0.2G Peak at 20 to 50Hz
Maximum elevation	Up to 1000 meters
Elevation for de-rated operation	Up to 2000 meters De-rate above 1000 meters-1% for every 100 meters

### Motor features:

- IE5+ motor efficiency
- FASR - Ferrite Assisted Synchronous Reluctance Rotor
- Class F insulation with Class B motor temperature rise
- IP54 motor enclosure with shaft seal
- Internal grounding brush for bearing current mitigation on DE retainer ring
- For inverter use only per NEMA MG1 Part 31.4.4.2
- 1.5 service factor design
- Designed for longevity with 3-year motor warranty

### Applications:

- Fans
- Pumps
- Compressors
- Blowers
- Unit handling
- HVAC systems
- Variable speed applications
- General purpose applications

### Drive features:

- Permanent magnet PWM AC drive control
- Serial modbus RJ45 interface
- 2 Digital inputs, 2 configurable inputs (analog or digital), 1 relay output
- Designed for longevity with 2-year drive warranty

### Standard product, motor and drive:

- IP54 gasket plastic drive enclosure and fan cover
- Built-in ABB Ability and bluetooth communications

### Plenum use product, motor and drive:

- IP54 gasket aluminum drive enclosure and fan cover
- Non-bluetooth drive

# EC Titanium™ motor, Inverter Duty, three phase, TEFC (totally enclosed fan cooled)

1 thru 20Hp



## Foot mounted

Hp	Base speed RPM	C.H. speed RPM	NEMA frame	Catalog number	"C" dim.	Aprx. wt. (lb)	Full load efficiency	Voltage	Full load amps
1	1800	4000	143T	ECS101M0H1DF4	12.29	28	89.3%	230/460	2.3/1.2
2	1800	4000	143T	ECS101M0H2DF4	12.29	35	90.7%	230/460	4.5/2.3
3	1800	4000	145T	ECS101M0H3DF4	13.29	44	91.4%	230/460	7.0/3.5
3	1800	4000	182T	ECS101M0H3EF4	16.54	59	92.8%	230/460	7.3/3.7
5	1800	4000	143T	ECS101M0H5DF4	15.54	64	93.0%	230/460	10.4/5.2
5	1800	4000	182T	ECS101M0H5EF4	16.54	68	93.7%	230/460	10.5/5.3
7.5	1800	4000	184T	ECS101M0H7EF4	18.04	92	94.0%	230/460	17.5/8.8
7.5	1800	3000	213T	ECS101M0H7FF4	17.89	105	94.0%	230/460	17.4/8.7
10	1800	3000	213T	ECS101M0H10FF4	19.02	123	94.8%	230/460	22.0/11.0
15	1800	3000	215T	ECS101M0H15FF4	21.96	168	95.6%	230/460	34.8/17.4
20	1800	3000	215T	ECS101M4H20FF4	23.51	218	95.9%	460	21.6

## C-Face foot mounted

Hp	Base speed RPM	C.H. speed RPM	NEMA frame	Catalog number	"C" dim.	Aprx. wt. (lb)	Full load efficiency	Voltage	Full load amps
1	1800	4000	143TC	ECS101M0H1DB4	12.29	28	89.3%	230/460	2.3/1.2
2	1800	4000	143TC	ECS101M0H2DB4	12.29	35	90.7%	230/460	4.5/2.3
3	1800	4000	145TC	ECS101M0H3DB4	13.29	44	91.4%	230/460	7.0/3.5
			182TC	ECS101M0H3EB4	16.54	59	92.8%	230/460	7.3/3.7
5	1800	4000	143TC	ECS101M0H5DB4	15.54	64	93.0%	230/460	10.4/5.2
			182TC	ECS101M0H5EB4	16.54	68	93.7%	230/460	10.5/5.3
7.5	1800	4000	184TC	ECS101M0H7EB4	18.04	92	94.0%	230/460	17.5/8.8
		3000	213TC	ECS101M0H7FB4	17.89	105	94.0%	230/460	17.4/8.7
10	1800	3000	213TC	ECS101M0H10FB4	19.02	123	94.8%	230/460	22.0/11.0
15	1800	3000	215TC	ECS101M0H15FB4	21.96	168	95.6%	230/460	34.8/17.4
20	1800	3000	215TC	ECS101M4H20FB4	23.51	218	95.9%	460	21.6

## C-Face footless

Hp	Base speed RPM	C.H. speed RPM	NEMA frame	Catalog number	"C" dim.	Aprx. wt. (lb)	Full load efficiency	Voltage	Full load amps
1	1800	4000	143TC	ECS101M0H1DC4	12.29	28	89.3%	230/460	2.3/1.2
2	1800	4000	143TC	ECS101M0H2DC4	12.29	35	90.7%	230/460	4.5/2.3
3	1800	4000	145TC	ECS101M0H3DC4	13.29	44	91.4%	230/460	7.0/3.5
			182TC	ECS101M0H3EC4	16.54	59	92.8%	230/460	7.3/3.7
5	1800	4000	143TC	ECS101M0H5DC4	15.54	64	93.0%	230/460	10.4/5.2
			182TC	ECS101M0H5EC4	16.54	68	93.7%	230/460	10.5/5.3
7.5	1800	4000	184TC	ECS101M0H7EC4	18.04	92	94.0%	230/460	17.5/8.8
		3000	213TC	ECS101M0H7FC4	17.89	105	94.0%	230/460	17.4/8.7
10	1800	3000	213TC	ECS101M0H10FC4	19.02	123	94.8%	230/460	22.0/11.0
15	1800	3000	215TC	ECS101M0H15FC4	21.96	168	95.6%	230/460	34.8/17.4
20	1800	3000	215TC	ECS101M4H20FC4	23.51	218	95.9%	460	21.6

# EC Titanium™, top mount, integrated drive motor, three phase, TEFC (totally enclosed fan cooled)

1 thru 10Hp



## Foot mounted

Hp	Base speed RPM	C.H. speed RPM	NEMA frame	Catalog number	"C" dim.	Aprx. wt. (lb)	Full load efficiency	Motor input amps	Drive input voltage	Drive module	Drive output amps
<b>1-phase 100V...115V AC (+/-10%) - 3-phase 230V output</b>											
1	1800	4000	143T	ECS100T1H1DF4	12.37	36	89.3%	2.4	115	ECI1A3P2	3.2
<b>1-phase 200...240V AC (+/-10%) - 3-phase 230V output</b>											
1	1800	4000	143T	ECS100T8H1DF4	12.37	35	89.3%	2.4	230	ECI8A7P0	7
2	1800	4000	145T	ECS100T8H2DF4	13.37	41	90.7%	4.4	230	ECI8A7P0	7
<b>3-phase 200...240V AC (+/-10%) - 3-phase 230V Output</b>											
1	1800	4000	143T	ECS100T2H1DF4	12.37	35	89.3%	2.4	230	ECI2A4P3	4.3
2	1800	4000	145T	ECS100T2H2DF4	13.37	41	90.7%	4.3	230	ECI2A7P0	7
3	1800	4000	182T	ECS100T2H3EF4	16.71	66	92.8%	7.3	230	ECI2A10P5	10.5
5	1800	4000	184T	ECS100T2H5EF4	16.71	77	93.7%	10.5	230	ECI2A10P5	10.5
<b>3-phase 380...480V AC (+/-10%) - 3-phase 460V output</b>											
1	1800	4000	143T	ECS100T4H1DF4	12.37	35	89.3%	1.2	460	ECI4A2P2	2.2
2	1800	4000	145T	ECS100T4H2DF4	13.37	41	90.7%	2.2	460	ECI4A2P2	2.2
3	1800	4000	145T	ECS100T4H3DF4	13.37	47	91.4%	3.5	460	ECI4A4P1	4.1
			182T	ECS100T4H3EF4	16.71	67	92.8%	3.7	460	ECI4A4P1	4.1
5	1800	4000	184T	ECS100T4H5EF4	16.71	77	93.7%	5.3	460	ECI4A5P8	5.8
			184T	ECS100T4H7EF4	18.21	106	94.0%	8.8	460	ECI4A9P5	9.5
7.5	1800	3000	213T	ECS100T4H7FF4	18.1	111	94.7%	8.6	460	ECI4A9P5	9.5
			215T	ECS100T4H10FF4	19.23	132	94.8%	11	460	ECI4A12P0	12

## C-Face foot mounted

Hp	Base speed RPM	C.H. speed RPM	NEMA frame	Catalog number	"C" dim.	Aprx. wt. (lb)	Full load efficiency	Motor input amps	Drive input voltage	Drive module	Drive output amps
<b>1-phase 100V...115V AC (+/-10%) - 3-phase 230V output</b>											
1	1800	4000	143TC	ECS100T1H1DB4	12.37	36	89.3%	2.4	115	ECI1A3P2	3.2
<b>1-phase 200...240V AC (+/-10%) - 3-phase 230V output</b>											
1	1800	4000	143TC	ECS100T8H1DB4	12.37	35	89.3%	2.4	230	ECI8A7P0	7
2	1800	4000	145TC	ECS100T8H2DB4	13.37	41	90.7%	4.4	230	ECI8A7P0	7
<b>3-phase 200...240V AC (+/-10%) - 3-phase 230V output</b>											
1	1800	4000	143TC	ECS100T2H1DB4	12.37	35	89.3%	2.4	230	ECI2A4P3	4.3
2	1800	4000	145TC	ECS100T2H2DB4	13.37	41	90.7%	4.3	230	ECI2A7P0	7
3	1800	4000	182TC	ECS100T2H3EB4	16.71	66	92.8%	7.3	230	ECI2A10P5	10.5
5	1800	4000	184TC	ECS100T2H5EB4	16.71	77	93.7%	10.5	230	ECI2A10P5	10.5
<b>3-phase 380...480V AC (+/-10%) - 3-phase 460V output</b>											
1	1800	4000	143TC	ECS100T4H1DB4	12.37	35	89.3%	1.2	460	ECI4A2P2	2.2
2	1800	4000	145TC	ECS100T4H2DB4	13.37	41	90.7%	2.2	460	ECI4A2P2	2.2
3	1800	4000	145TC	ECS100T4H3DB4	13.37	47	91.4%	3.5	460	ECI4A4P1	4.1
			182TC	ECS100T4H3EB4	16.71	67	92.8%	3.7	460	ECI4A4P1	4.1
5	1800	4000	184TC	ECS100T4H5EB4	16.71	77	93.7%	5.3	460	ECI4A5P8	5.8
			184TC	ECS100T4H7EB4	18.21	106	94.0%	8.8	460	ECI4A9P5	9.5
7.5	1800	3000	213TC	ECS100T4H7FB4	18.1	111	94.7%	8.6	460	ECI4A9P5	9.5
			215TC	ECS100T4H10FB4	19.23	132	94.8%	11	460	ECI4A12P0	12

## C-Face footless

Hp	Base speed RPM	C.H. speed RPM	NEMA frame	Catalog number	"C" dim.	Aprx. wt. (lb)	Full load efficiency	Motor input amps	Drive input voltage	Drive module	Drive output amps
<b>1-phase 100V...115V AC (+/-10%) - 3-phase 230V output</b>											
1	1800	4000	143TC	ECS100T1H1DC4	12.37	36	89.3%	2.4	115	ECI1A3P2	3.2
<b>1-phase 200...240V AC (+/-10%) - 3-phase 230V output</b>											
1	1800	4000	143TC	ECS100T8H1DC4	12.37	35	89.3%	2.4	230	ECI8A7P0	7
2	1800	4000	145TC	ECS100T8H2DC4	13.37	41	90.7%	4.4	230	ECI8A7P0	7
<b>3-phase 200...240V AC (+/-10%) - 3-phase 230V output</b>											
1	1800	4000	143TC	ECS100T2H1DC4	12.37	35	89.3%	2.4	230	ECI2A4P3	4.3
2	1800	4000	145TC	ECS100T2H2DC4	13.37	41	90.7%	4.3	230	ECI2A7P0	7
3	1800	4000	182TC	ECS100T2H3EC4	16.71	66	92.8%	7.3	230	ECI2A10P5	10.5
5	1800	4000	184TC	ECS100T2H5EC4	16.71	77	93.7%	10.5	230	ECI2A10P5	10.5
<b>3-phase 380...480V AC (+/-10%) - 3-phase 460V output</b>											
1	1800	4000	143TC	ECS100T4H1DC4	12.37	35	89.3%	1.2	460	ECI4A2P2	2.2
2	1800	4000	145TC	ECS100T4H2DC4	13.37	41	90.7%	2.2	460	ECI4A2P2	2.2
3	1800	4000	145TC	ECS100T4H3DC4	13.37	47	91.4%	3.5	460	ECI4A4P1	4.1
			182TC	ECS100T4H3EC4	16.71	67	92.8%	3.7	460	ECI4A4P1	4.1
5	1800	4000	184TC	ECS100T4H5EC4	16.71	77	93.7%	5.3	460	ECI4A5P8	5.8
			184TC	ECS100T4H7EC4	18.21	106	94.0%	8.8	460	ECI4A9P5	9.5
7.5	1800	3000	213TC	ECS100T4H7FC4	18.1	111	94.7%	8.6	460	ECI4A9P5	9.5
			215TC	ECS100T4H10FC4	19.23	132	94.8%	11	460	ECI4A12P0	12

# EC Titanium™, axial mount, integrated drive motor, three phase, TEFC (totally enclosed fan cooled)

1 thru 7.5Hp



## Foot mounted

Hp	Base speed RPM	C.H. speed RPM	NEMA frame	Catalog number	"C" dim.	Aprx. wt. (lb)	Full load efficiency	Motor input amps	Drive input voltage	Drive module	Drive output amps
<b>1-phase 100V...115V AC (+/-10%) - 3-phase 230V output</b>											
1	1800	4000	143T	ECS100A1H1DF4	16.71	36	89.3%	2.4	115	ECI1A3P2	3.2
<b>1-phase 200...240V AC (+/-10%) - 3-phase 230V output</b>											
1	1800	4000	143T	ECS100A8H1DF4	16.71	35	89.3%	2.4	230	ECI8A7P0	7
2	1800	4000	145T	ECS100A8H2DF4	16.71	41	90.7%	4.4	230	ECI8A7P0	7
<b>3-phase 200...240V AC (+/-10%) - 3-phase 230V output</b>											
1	1800	4000	143T	ECS100A2H1DF4	16.71	35	89.3%	2.4	230	ECI2A4P3	4.3
2	1800	4000	145T	ECS100A2H2DF4	16.71	41	90.7%	4.3	230	ECI2A7P0	7
3	1800	4000	182T	ECS100A2H3EF4	22.25	66	92.8%	7.3	230	ECI2A10P5	10.5
5	1800	4000	184T	ECS100A2H5EF4	22.25	77	93.7%	10.5	230	ECI2A10P5	10.5
<b>3-phase 380...480V AC (+/-10%) - 3-phase 460V output</b>											
1	1800	4000	143T	ECS100A4H1DF4	16.71	35	89.3%	1.2	460	ECI4A2P2	2.2
2	1800	4000	145T	ECS100A4H2DF4	16.71	41	90.7%	2.2	460	ECI4A2P2	2.2
3	1800	4000	145T	ECS100A4H3DF4	16.71	47	91.4%	3.5	460	ECI4A4P1	4.1
			182T	ECS100A4H3EF4	22.25	67	92.8%	3.7	460	ECI4A4P1	4.1
5	1800	4000	184T	ECS100A4H5EF4	22.25	77	93.7%	5.3	460	ECI4A5P8	5.8
7.5	1800	4000	184T	ECS100A4H7EF4	23.76	106	94.0%	8.8	460	ECI4A9P5	9.5

## C-Face foot mounted

Hp	Base speed RPM	C.H. speed RPM	NEMA frame	Catalog number	"C" dim.	Aprx. wt. (lb)	Full load efficiency	Motor input amps	Drive input voltage	Drive module	Drive output amps
<b>1-phase 100V...115V AC (+/-10%) - 3-phase 230V output</b>											
1	1800	4000	143TC	ECS100A1H1DB4	16.71	36	89.3%	2.4	115	ECI1A3P2	3.2
<b>1-phase 200...240V AC (+/-10%) - 3-phase 230V output</b>											
1	1800	4000	143TC	ECS100A8H1DB4	16.71	35	89.3%	2.4	230	ECI8A7P0	7
2	1800	4000	145TC	ECS100A8H2DB4	16.71	41	90.7%	4.4	230	ECI8A7P0	7
<b>3-phase 200...240V AC (+/-10%) - 3-phase 230V output</b>											
1	1800	4000	143TC	ECS100A2H1DB4	16.71	35	89.3%	2.4	230	ECI2A4P3	4.3
2	1800	4000	145TC	ECS100A2H2DB4	16.71	41	90.7%	4.3	230	ECI2A7P0	7
3	1800	4000	182TC	ECS100A2H3EB4	22.25	66	92.8%	7.3	230	ECI2A10P5	10.5
5	1800	4000	184TC	ECS100A2H5EB4	22.25	77	93.7%	10.5	230	ECI2A10P5	10.5
<b>3-phase 380...480V AC (+/-10%) - 3-phase 460V output</b>											
1	1800	4000	143TC	ECS100A4H1DB4	16.71	35	89.3%	1.2	460	ECI4A2P2	2.2
2	1800	4000	145TC	ECS100A4H2DB4	16.71	41	90.7%	2.2	460	ECI4A2P2	2.2
3	1800	4000	145TC	ECS100A4H3DB4	16.71	47	91.4%	3.5	460	ECI4A4P1	4.1
			182TC	ECS100A4H3EB4	22.25	67	92.8%	3.7	460	ECI4A4P1	4.1
5	1800	4000	184TC	ECS100A4H5EB4	22.25	77	93.7%	5.3	460	ECI4A5P8	5.8
7.5	1800	4000	184TC	ECS100A4H7EB4	23.76	106	94.0%	8.8	460	ECI4A9P5	9.5

## C-Face footless

Hp	Base speed RPM	C.H. speed RPM	NEMA frame	Catalog number	"C" dim.	Aprx. wt. (lb)	Full load efficiency	Motor input amps	Drive input voltage	Drive module	Drive output amps
<b>1-phase 100V...115V AC (+/-10%) - 3-phase 230V output</b>											
1	1800	4000	143TC	ECS100A1H1DC4	16.71	36	89.3%	2.4	115	ECI1A3P2	3.2
<b>1-phase 200...240V AC (+/-10%) - 3-phase 230V output</b>											
1	1800	4000	143TC	ECS100A8H1DC4	16.71	35	89.3%	2.4	230	ECI8A7P0	7
2	1800	4000	145TC	ECS100A8H2DC4	16.71	41	90.7%	4.4	230	ECI8A7P0	7
<b>3-phase 200...240V AC (+/-10%) - 3 Phase 230V output</b>											
1	1800	4000	143TC	ECS100A2H1DC4	16.71	35	89.3%	2.4	230	ECI2A4P3	4.3
2	1800	4000	145TC	ECS100A2H2DC4	16.71	41	90.7%	4.3	230	ECI2A7P0	7
3	1800	4000	182TC	ECS100A2H3EC4	22.25	66	92.8%	7.3	230	ECI2A10P5	10.5
5	1800	4000	184TC	ECS100A2H5EC4	22.25	77	93.7%	10.5	230	ECI2A10P5	10.5
<b>3-phase 380...480V AC (+/-10%) - 3-phase 460V output</b>											
1	1800	4000	143TC	ECS100A4H1DC4	16.71	35	89.3%	1.2	460	ECI4A2P2	2.2
2	1800	4000	145TC	ECS100A4H2DC4	16.71	41	90.7%	2.2	460	ECI4A2P2	2.2
3	1800	4000	145TC	ECS100A4H3DC4	16.71	47	91.4%	3.5	460	ECI4A4P1	4.1
			182TC	ECS100A4H3EC4	22.25	67	92.8%	3.7	460	ECI4A4P1	4.1
5	1800	4000	184TC	ECS100A4H5EC4	22.25	77	93.7%	5.3	460	ECI4A5P8	5.8
7.5	1800	4000	184TC	ECS100A4H7EC4	23.76	106	94.0%	8.8	460	ECI4A9P5	9.5

**EC Titanium™, plenum use, top mount**  
**integrated drive motor, TEFC (totally enclosed fan cooled)**

1 thru 10Hp



Hp	Base speed RPM	C.H. speed RPM	NEMA frame	Catalog number	"C" dim.	Aprx. wt. (lb)	Full load efficiency	Motor input amps	Drive input voltage	Drive module	Drive output amps
<b>1-phase 100V...115V AC (+/-10%) - 3-phase 230V output</b>											
1	1800	4000	143T	ECS101T1H1DF4	16.71	36	89.3%	2.4	115	ECIN1A3P2	3.2
<b>1-phase 200...240V AC (+/-10%) - 3-phase 230V output</b>											
1	1800	4000	143T	ECS101T8H1DF4	16.71	35	89.3%	2.4	230	ECIN8A7P0	7
2	1800	4000	145T	ECS101T8H2DF4	16.71	41	90.7%	4.4	230	ECIN8A7P0	7
<b>3-phase 200...240V AC (+/-10%) - 3-phase 230V output</b>											
1	1800	4000	143T	ECS101T2H1DF4	16.71	35	89.3%	2.4	230	ECIN2A4P3	4.3
2	1800	4000	145T	ECS101T2H2DF4	16.71	41	90.7%	4.3	230	ECIN2A7P0	7
3	1800	4000	182T	ECS101T2H3EF4	22.25	66	92.8%	7.3	230	ECIN2A10P5	10.5
5	1800	4000	184T	ECS101T2H5EF4	22.25	77	93.7%	10.5	230	ECIN2A10P5	10.5
<b>3-phase 380...480V AC (+/-10%) - 3-phase 460V output</b>											
1	1800	4000	143T	ECS101T4H1DF4	16.71	35	89.3%	1.2	460	ECIN4A2P2	2.2
2	1800	4000	145T	ECS101T4H2DF4	16.71	41	90.7%	2.2	460	ECIN4A2P2	2.2
3	1800	4000	145T	ECS101T4H3DF4	16.71	47	91.4%	3.5	460	ECIN4A4P1	4.1
			182T	ECS101T4H3EF4	22.25	67	92.8%	3.7	460	ECIN4A4P1	4.1
5	1800	4000	184T	ECS101T4H5EF4	22.25	77	93.7%	5.3	460	ECIN4A5P8	5.8
7.5	1800	4000	184T	ECS101T4H7EF4	23.76	106	94.0%	8.8	460	ECIN4A9P5	9.5
		3000	213T	ECS101T4H7FF4	18.1	111	94.7%	8.6	460	ECIN4A9P5	9.5
10	1800	3000	215T	ECS101T4H10FF4	19.23	132	94.8%	11	460	ECIN4A12P0	12

**EC Titanium™, plenum use, axial mount**  
**integrated drive motor, TEFC (totally enclosed fan cooled)**

1 thru 7.5Hp



Hp	Base speed RPM	C.H. speed RPM	NEMA frame	Catalog number	"C" dim.	Aprx. wt. (lb)	Full load efficiency	Motor input amps	Drive input voltage	Drive module	Drive output amps
<b>1-phase 100V...115V AC (+/-10%) - 3-phase 230V output</b>											
1	1800	4000	143T	ECS101A1H1DF4	16.71	36	89.3%	2.4	115	ECIN1A3P2	3.2
<b>1-phase 200...240V AC (+/-10%) - 3-phase 230V output</b>											
1	1800	4000	143T	ECS101A8H1DF4	16.71	35	89.3%	2.4	230	ECIN8A7P0	7
2	1800	4000	145T	ECS101A8H2DF4	16.71	41	90.7%	4.4	230	ECIN8A7P0	7
<b>3-phase 200...240V AC (+/-10%) - 3-phase 230V output</b>											
1	1800	4000	143T	ECS101A2H1DF4	16.71	35	89.3%	2.4	230	ECIN2A4P3	4.3
2	1800	4000	145T	ECS101A2H2DF4	16.71	41	90.7%	4.3	230	ECIN2A7P0	7
3	1800	4000	182T	ECS101A2H3EF4	22.25	66	92.8%	7.3	230	ECIN2A10P5	10.5
5	1800	4000	184T	ECS101A2H5EF4	22.25	77	93.7%	10.5	230	ECIN2A10P5	10.5
<b>3-phase 380...480V AC (+/-10%) - 3-phase 460V output</b>											
1	1800	4000	143T	ECS101A4H1DF4	16.71	35	89.3%	1.2	460	ECIN4A2P2	2.2
2	1800	4000	145T	ECS101A4H2DF4	16.71	41	90.7%	2.2	460	ECIN4A2P2	2.2
3	1800	4000	145T	ECS101A4H3DF4	16.71	47	91.4%	3.5	460	ECIN4A4P1	4.1
			182T	ECS101A4H3EF4	22.25	67	92.8%	3.7	460	ECIN4A4P1	4.1
5	1800	4000	184T	ECS101A4H5EF4	22.25	77	93.7%	5.3	460	ECIN4A5P8	5.8
7.5	1800	4000	184T	ECS101A4H7EF4	23.76	106	94.0%	8.8	460	ECIN4A9P5	9.5

## Programming and condition monitoring

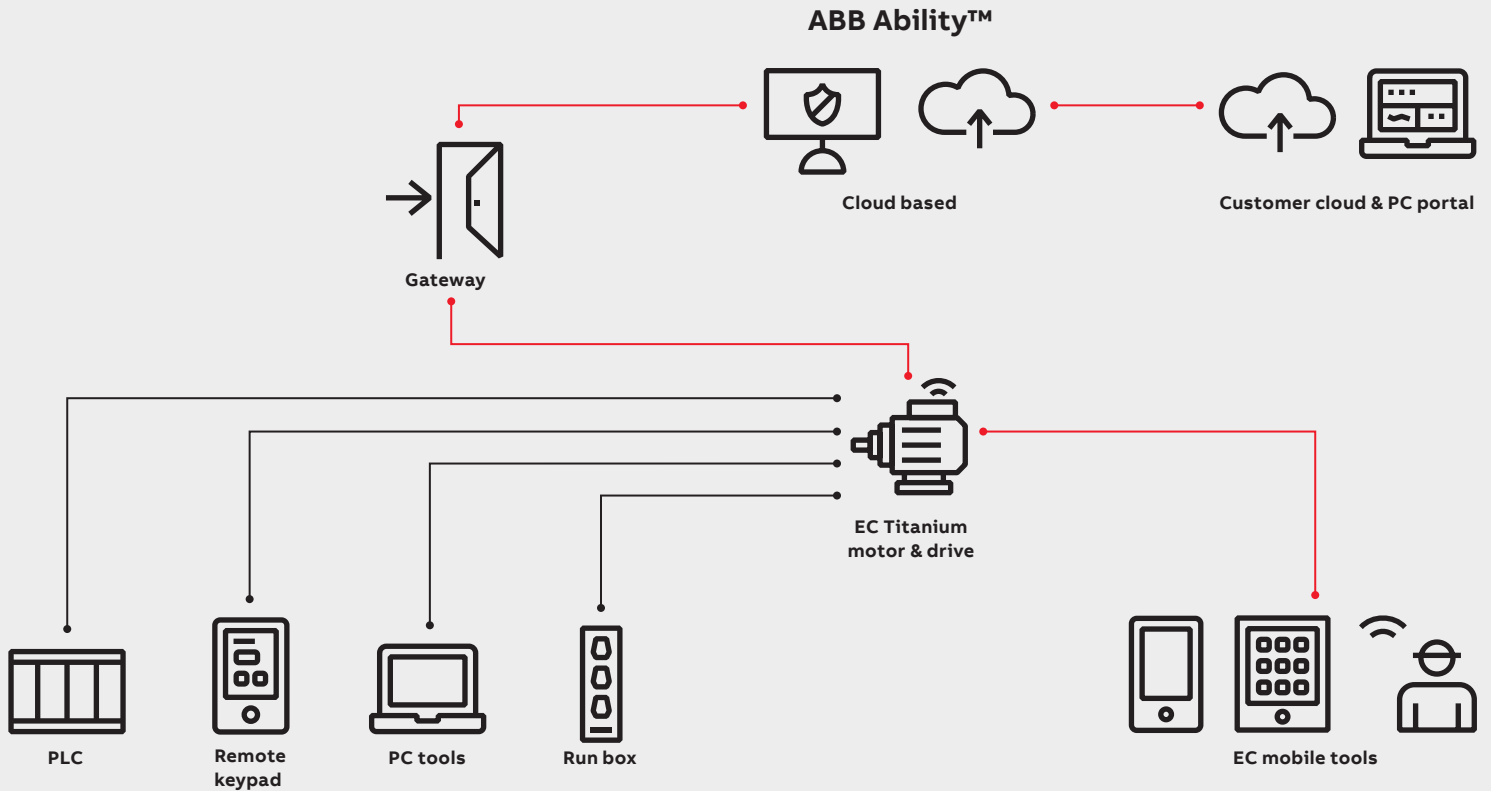

### ABB Ability Drive parameters

- Drive module temperature
- Drive control board temperature
- DC bus voltage
- Estimated speed
- Output frequency
- Output voltage
- DC bus ripple
- Status word/fault word
- DI status word
- Motor power
- Motor torque

For EC Titanium eTools, scan the QR code for information.

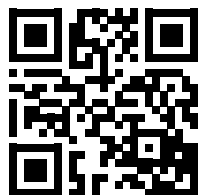

### EC Titanium, programming keypad & cable kits

	Catalog number
<b>Remote Keypad</b> Designed for programming and control of the EC Titanium. Kits comes with a 3-meter RJ45 cable	<b>ECS100L</b>
<b>COPYSTICK2</b> The COPYSTICK2 is used for fast and accurate repeat drive programming.	<b>ECS100B</b>
<b>RJ45 to USB Cable</b> PC connection kit, isolated RJ45 to USB cable for ECM software tools. This kit is used when programming the drive with the PC software tools.	<b>ECS100U</b>





# Dimensions

## EC Titanium - motor only

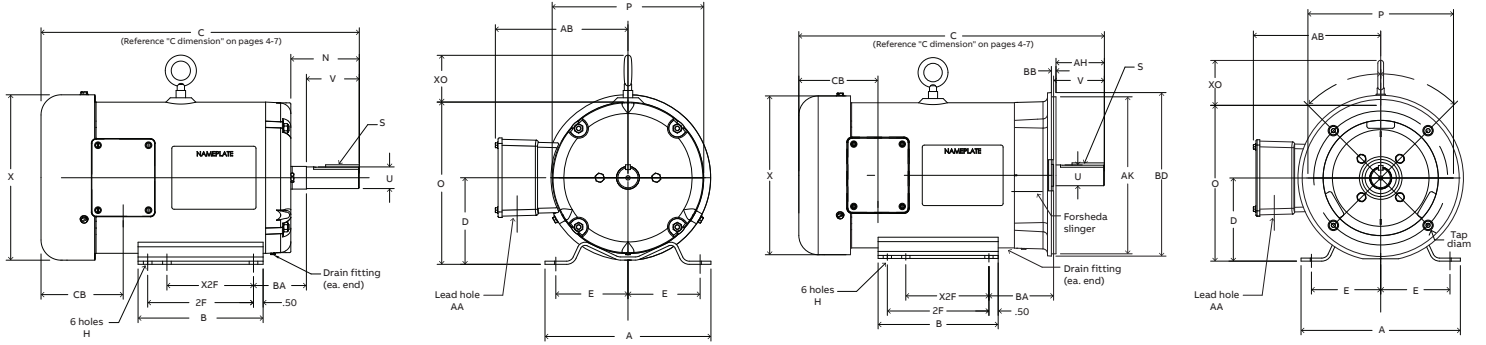

Foot mounted

C-Face foot mount

NEMA frame	CB	D	E	2F	X2F	B	H	N	O	X	P	U
<b>Foot mount</b>	<b>Dual foot mounts</b>											
140	3.75	3.5	2.75	5.00	4.00	5.94	0.38	2.50	6.81	7.19	6.62	0.875
180	4.26	4.5	3.75	5.50	4.50	6.50	0.41	3.56	8.43	8.60	7.88	1.250
210	5.01	5.25	4.25	7.00	5.50	8.00	0.41	3.88	10.03	10.28	9.57	1.375
<b>C-Face foot mount</b>												
140	3.78	3.5	2.75	5.00	4.00	5.94	0.38	-	6.81	7.19	6.62	0.875
180	4.26	4.5	3.75	5.50	4.50	6.50	0.41	-	8.43	8.60	7.88	1.250
210	5.01	5.25	4.25	7.00	5.50	8.00	0.41	-	10.03	10.28	9.57	1.375
<b>C-Face footless</b>												
140	3.78	-	-	-	-	-	-	-	-	7.19	6.62	0.875
180	4.26	-	-	-	-	-	-	-	-	8.60	7.88	1.250
210	5.01	-	-	-	-	-	-	-	-	10.28	9.57	1.375

NEMA frame	S	V	AA	AB	A	AH	AK	BA	BB	BD	XO	TAP	Diam B.C.
<b>Foot mount</b>													
140	0.19	2.25	1.09	5.71	6.50	-	-	2.25	-	-	-	-	-
180	0.25	2.75	1.09	6.87	8.63	-	-	2.75	-	-	2.43	-	-
210	0.31	3.38	1.38	8.02	9.50	-	-	3.50	-	-	2.39	-	-
<b>C-Face foot mount</b>													
140	0.19	-	1.09	5.71	6.50	2.12	4.50	2.75	0.13	6.49	-	0.38 - 16	5.87
180	0.25	2.75	1.09	6.87	8.63	2.62	8.50	3.50	0.25	8.85	2.43	0.50 - 13	7.25
210	0.31	-	1.38	8.06	9.50	3.12	8.50	4.50	0.25	9.05	2.39	0.50 - 13	7.25
<b>C-Face footless</b>													
140	0.19	-	1.09	5.71	-	2.12	4.50	-	0.13	6.49	-	0.38 - 16	5.87
180	0.25	2.75	1.09	6.87	-	2.62	8.50	-	0.25	8.85	2.43	0.50 - 13	7.25
210	0.31	-	1.38	8.06	-	3.12	8.50	-	0.25	9.05	2.39	0.50 - 13	7.25

# Dimensions

## EC Titanium - top mounting

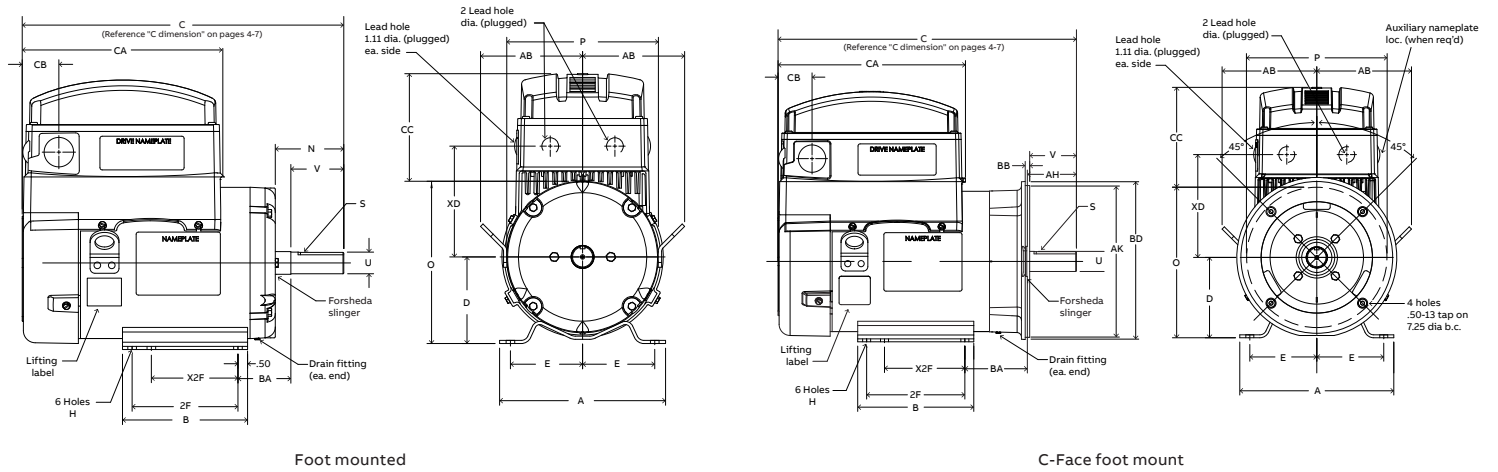

NEMA frame	CB	CA	CC	D	E	2F	X2F	B	H	N	O	XD	P
<b>Foot mount</b>	<b>Dual foot mounts</b>												
140	1.79	8.49	5.07	3.5	2.75	5.00	4.00	5.94	0.38	2.50	6.81	5.00	7.16
180	1.9	10.49	5.59	4.5	3.75	5.50	4.50	6.50	0.44	3.56	8.43	5.76	7.88
210	1.9	10.49	5.57	5.25	4.25	7.00	5.50	8.00	0.43	3.88	10.03	6.58	9.57
<b>C-Face foot mount</b>													
140	1.79	8.49	5.07	3.5	2.75	5.00	4.00	5.94	0.38	-	6.81	5.00	6.62
180	1.9	10.49	5.59	4.5	3.75	5.50	4.50	6.50	0.44	-	8.43	5.76	7.88
210	1.9	10.49	5.57	5.25	4.25	7.00	5.50	8.00	0.43	-	10.03	6.58	9.57
<b>C-Face footless</b>													
140	1.77	8.49	5.07	-	-	-	-	-	-	-	-	5.00	6.62
180	1.9	10.49	5.59	-	-	-	-	-	-	-	-	5.76	7.88
210	1.9	10.49	5.57	-	-	-	-	-	-	-	-	6.58	9.57

NEMA frame	U	S	V	AB	A	AH	AK	BA	BB	BD	TAP	Diam B.C.
<b>Foot mount</b>												
140	0.875	0.19	2.25	-	6.50	-	-	2.25	-	-	-	-
180	1.250	0.25	2.75	5.30	8.63	-	-	2.75	-	-	-	-
210	1.375	0.31	3.38	5.38	9.50	-	-	3.50	-	-	-	-
<b>C-Face foot mount</b>												
140	0.875	0.19	-	-	6.50	2.12	4.50	2.75	0.13	6.49	0.38 - 16	5.87
180	1.250	0.25	2.75	5.30	8.63	2.62	8.50	3.50	0.25	8.85	0.50 - 13	7.25
210	1.375	0.31	-	5.38	9.50	3.12	8.50	4.50	0.25	9.05	0.50 - 13	7.25
<b>C-Face footless</b>												
140	0.875	0.19	-	-	-	2.12	4.50	-	0.13	6.49	0.38 - 16	5.87
180	1.250	0.25	2.75	5.30	-	2.62	8.50	-	0.25	8.85	0.50 - 13	7.25
210	1.375	0.31	-	5.38	-	3.12	8.50	-	0.25	9.05	0.50 - 13	7.25

# Dimensions

## EC Titanium - axial mounting

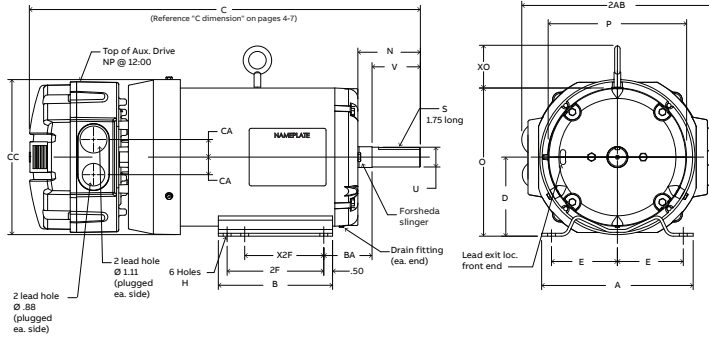

Foot mounted

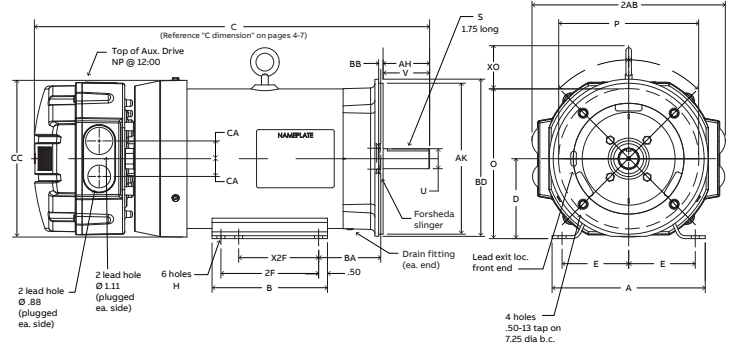

C-Face foot mount

NEMA frame	CA	CC	D	E	2F	X2F	B	H	N	O	P
<b>Foot mount</b>	<b>Dual foot mounts</b>										
140	0.81	7.23	3.5	2.75	5.00	4.00	5.94	0.38	2.50	6.81	6.61
180	1.00	8.82	4.5	3.75	5.50	4.50	6.50	0.44	3.56	8.43	7.88
<b>C-Face foot mount</b>											
140	0.81	7.23	3.5	2.75	5.00	4.00	5.94	0.38	-	6.81	6.61
180	1.00	8.82	4.5	3.75	5.50	4.50	6.50	0.44	-	8.43	7.88
<b>C-Face footless</b>											
140	0.81	7.23	-	-	-	-	-	-	-	-	6.61
180	1.00	8.82	-	-	-	-	-	-	-	-	7.88

NEMA frame	U	S	V	2AB	A	AH	AK	BA	BB	BD	XO	TAP	Diam B.C.
<b>Foot mount</b>													
140	0.875	0.19	2.25	8.06	6.50	-	-	2.25	-	-	-	-	-
180	1.250	0.25	2.75	10.89	8.63	-	-	2.75	-	-	2.43	-	-
<b>C-Face foot mount</b>													
140	0.875	0.19	-	8.06	6.50	2.12	4.50	2.75	0.13	6.49	-	0.38 - 16	5.87
180	1.250	0.25	2.75	10.89	8.63	2.62	8.50	3.50	0.25	8.85	2.43	0.50 - 13	7.25
<b>C-Face footless</b>													
140	0.875	0.19	-	8.06	-	2.12	4.50	-	0.13	6.49	-	0.38 - 16	5.87
180	1.250	0.25	2.75	10.89	-	2.62	8.50	-	0.25	8.85	-	0.50 - 13	7.25

---

ABB Motors and Mechanical Inc.  
5711 R.S. Boreham, Jr. Street  
Fort Smith, AR 72901  
Ph: 1.479.646.4711

**[new.abb.com/motors-generators](http://new.abb.com/motors-generators)**