

ABB DRIVES AND MOTORS

Achieve maximum efficiency on your stationary compressors



**ABB's comprehensive drive offering
for different type of compressors to get
the maximum efficiency and control.**

Table of contents

04–05	Compression at maximum efficiency
06–07	Air compressors
08–09	High-speed compressors and blowers
10–11	Industrial and commercial cooling compressors
12–13	Cooling compressors in food and beverage
14–15	ABB drives and PLCs for compressor applications
16–17	All-compatible drives for compressors
18–19	Program your drive with ABB tools
20	Best motor control and highest energy efficiency
21	Wide range of motors for different types of compressors
22–23	Our service expertise, your advantage
24–25	ABB drives life cycle management

Smooth startup. Accurate pressure control. Reliability. Energy savings. Everything counts.

Compressor rooms can be hot and dusty, which makes for a very demanding environment for power electronics. In addition, the load profile of the compressor is highly cyclical, which causes extra stress. Therefore the power electronics operating in these conditions must be of the highest quality. ABB drives are built to handle this and they are very well protected against the hostile environments and stress related to compressor operations.

Our product offering improves reliability and gives you many advantages in compressor systems. The latest innovations from ABB drives and motors help OEMs build state of the art compressors in terms of performance and quality. We can help you select and size drives to meet your requirements. A wide range of components from one supplier simplifies the ordering process and saves you time.

On most industrial sites, the demand for compressed air or refrigeration can vary according to time, day or season. If a compressor is not able to adjust compression by varying the speed of the motor, the energy bill will be unnecessarily high. Variable speed drive technology can help you solve this.

Our drives help you save energy during consumption under partial loads. The drives will vary the speed of the compressor motor to correspond to the actual demand. They also react quickly to changes in demand, so you do not have to run at higher discharge pressures than necessary to compensate. We offer a wide selection of PLCs, operator panels and low voltage products, such as circuit breakers, that can be easily integrated with all of the ABB components. By working closely together with OEMs, ABB has developed an automation product offering that enables precise, dependable and energy-efficient compressor operation.



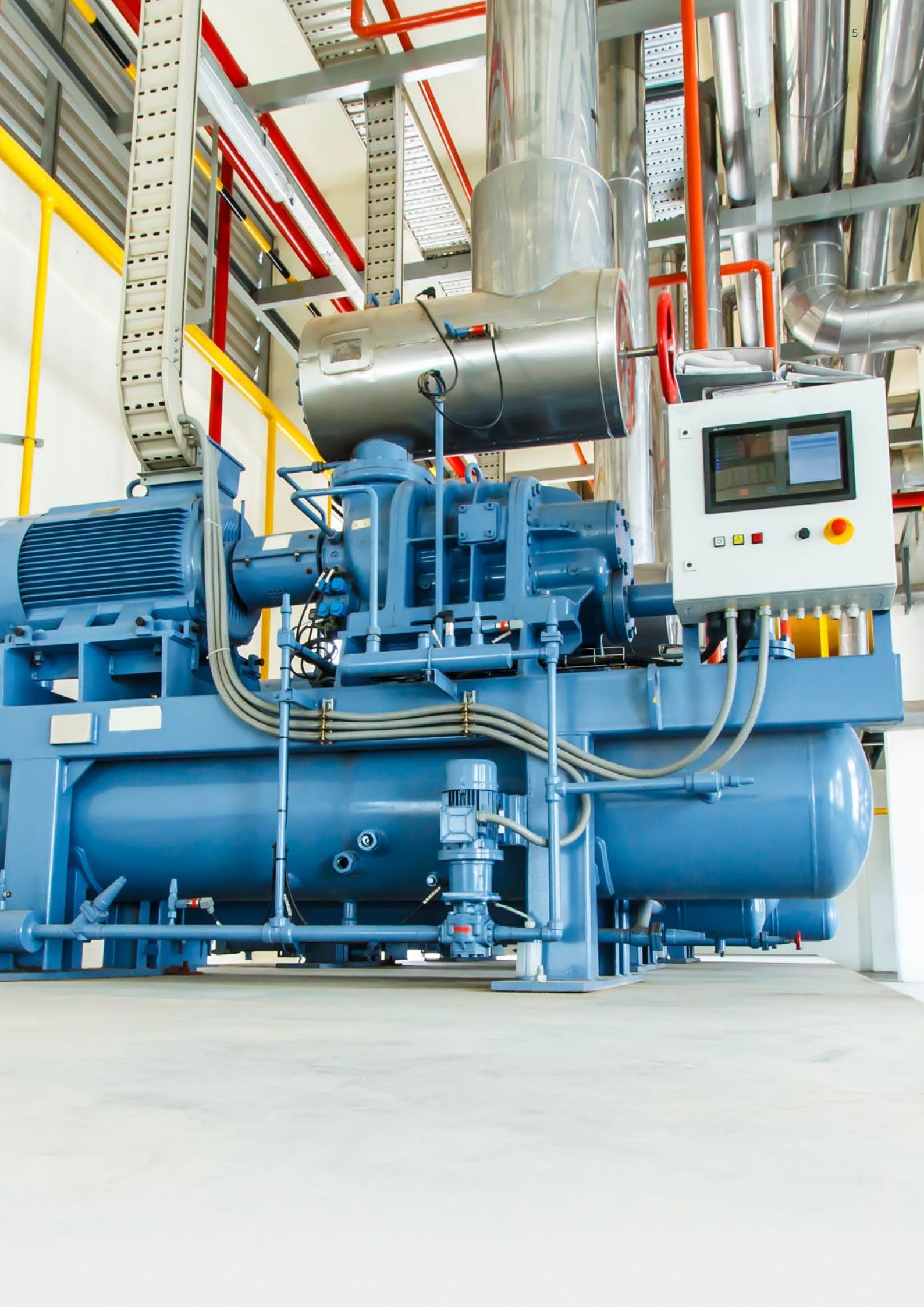

Air compressors

Air compressor rooms can include one or several parallel-connected stationary compressors. To make sure compressed air is available at all times, the mechanical and electrical quality of the compressor is vital.

One compressor station can include many electrical components, like motors and drives for cooling, pumps for condensation water and lubricating oil, as well as air dryer and compression elements. Heat and dust combine to make the compressor environment very demanding for electrical components.

ABB has a range of equipment that makes precise control of compressors easy and efficient, including:

- PLCs and HMIs with adaptive and IEC 61131-3 programming customized to the precise application needs
- ABB's partner B&R can provide complete hardware and software packages for compressor control

Motors for compression and cooling

- An extensive selection of cast iron motors ensures the right motor can be found for any type of compressor
- IE5 synchronous reluctance motors (SynRM) and drive packages provide high efficiency without the use of permanent magnets

Our variable speed drives quickly react to discharge pressure differences and have the torque control needed to keep the pressure stable, from high-torque demands at startup to continual use.

- With variable speed control, energy savings can be achieved through lower consumption at partial loads
- Several motor control methods, like vector, scalar and direct torque control (DTC)
- Our drives support virtually any type of motor, including high-speed motors
- With integrated safe torque off (STO) for machinery safety as a standard, you are able to achieve the SIL 3 safety level for the compressor and without the need for a separate main contactor
- Flange mounting of the drive is an option for better thermal management
- Bluetooth control panels support also remote access over the Internet



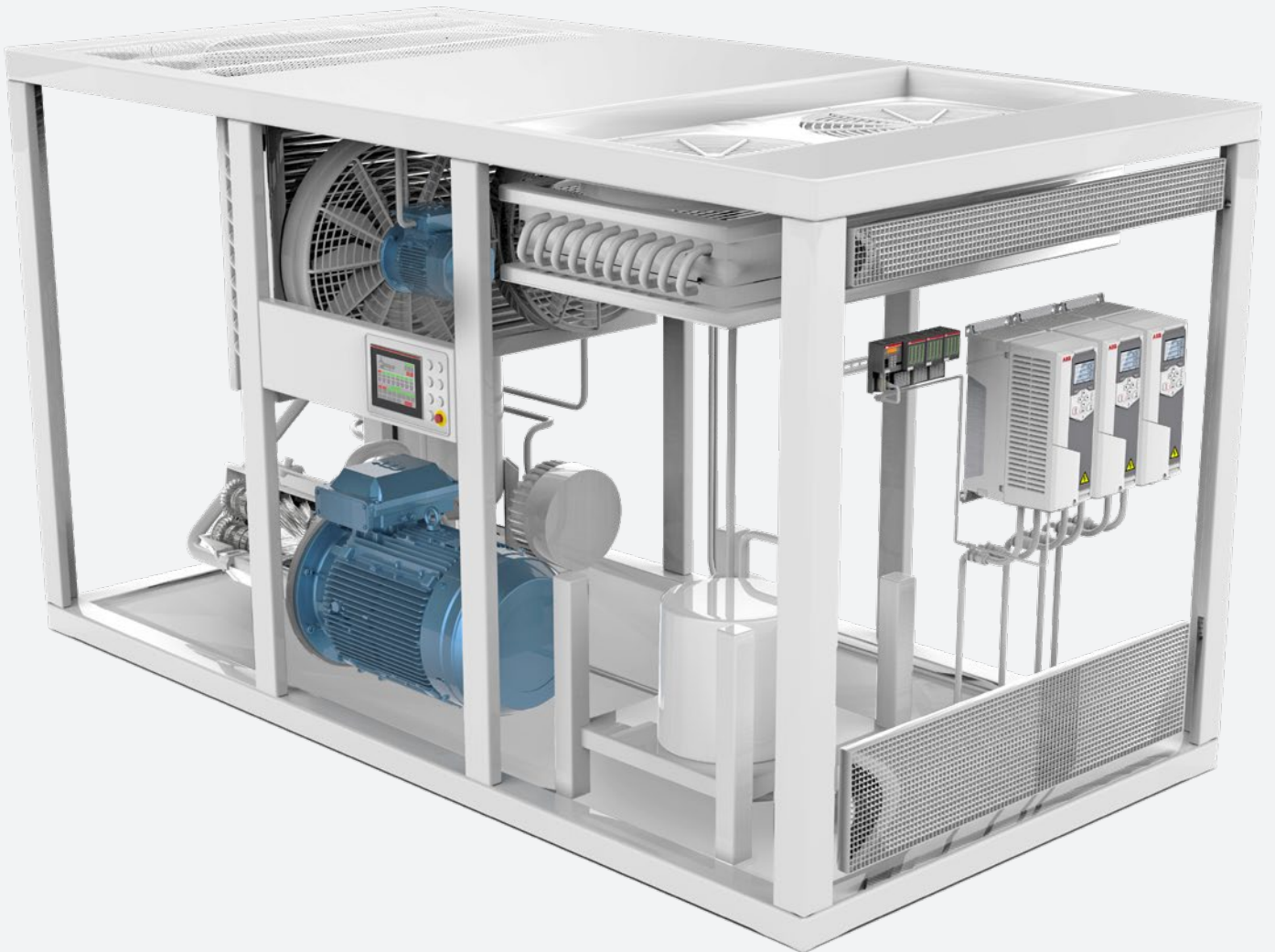

High-speed compressors and blowers

Advanced turbo blowers, and cooling and refrigeration compressors, can run at very high-speeds and therefore require state of the art compressor technology. This also challenges the motor control and hardware requirements of variable speed drives. ABB has developed an application-specific option for high-speed motors (+N7500), delivering optimized performance in a compact frame size.

Aeration turbo compressors are today widely used in wastewater plants. They are the most common high-power compressor application. A wastewater plant can get as much as 45% energy savings by using high-speed turbo blowers when compared to traditional compressor technology. High-speed compression is also used in industrial scale refrigeration compressors. High-speed motors used in industrial chillers are allowing remarkable energy savings also in refrigeration applications.

Currently, high-speed motor technology doesn't offer standard sizing, which is common for traditional motors. The drive's motor control, must be flexible enough to be able to control all kinds of high-speed motor types. The drive doesn't only need to match the requirements of various motor types, but it also needs to have capacity to supply enough current to the motor.

By using an ACS880 drive you get the following benefits in high-speed applications:

- Support for various high-speed motor types, with and without sine filters
- Wide power and voltage range, and large number of product options help you find the right drive for your whole portfolio
- Compact drive size including a built-in input choke helps you reduce the cabinet size and makes machine design and component installation easier
- Pre-sales support with drive type and sine filter recommendations, as well as remote drive commissioning support, are available from ABB's worldwide OEM hubs
- Peace of mind, knowing that your high-speed compressor is designed for reliable 24/7 operation and the drive can meet this challenge year after year, even in harsh conditions
- Our high-speed drives lifecycle program guarantees spare parts and long lifetime warranty if required

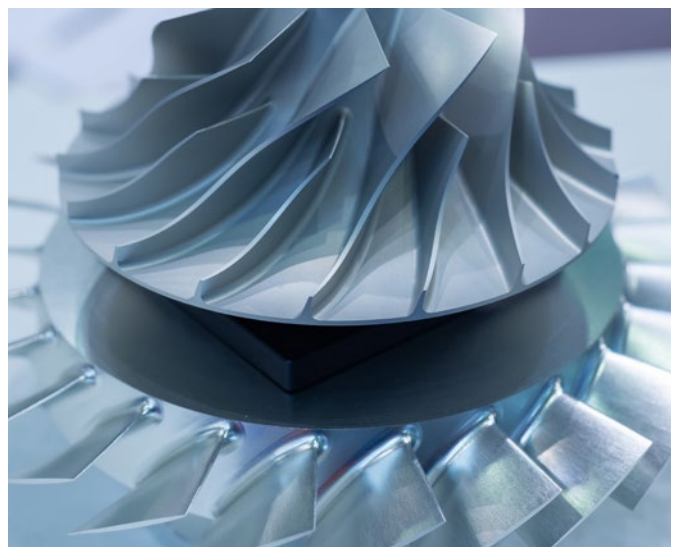



Industrial and commercial cooling compressors

In an industrial or commercial compressor cooling system, liquid loops are responsible for regulating the temperature. To accomplish this, a number of applications must work together: compressor, condenser, evaporator, chiller and pumps. ABB's drive and motor technology can help optimize all of these operations.

Condenser unit

ABB drives and motors offer a game-changing solution for a condenser unit. ACH580 drive can control up to 16 EC Titanium motors for an energy efficient IE5 solution.

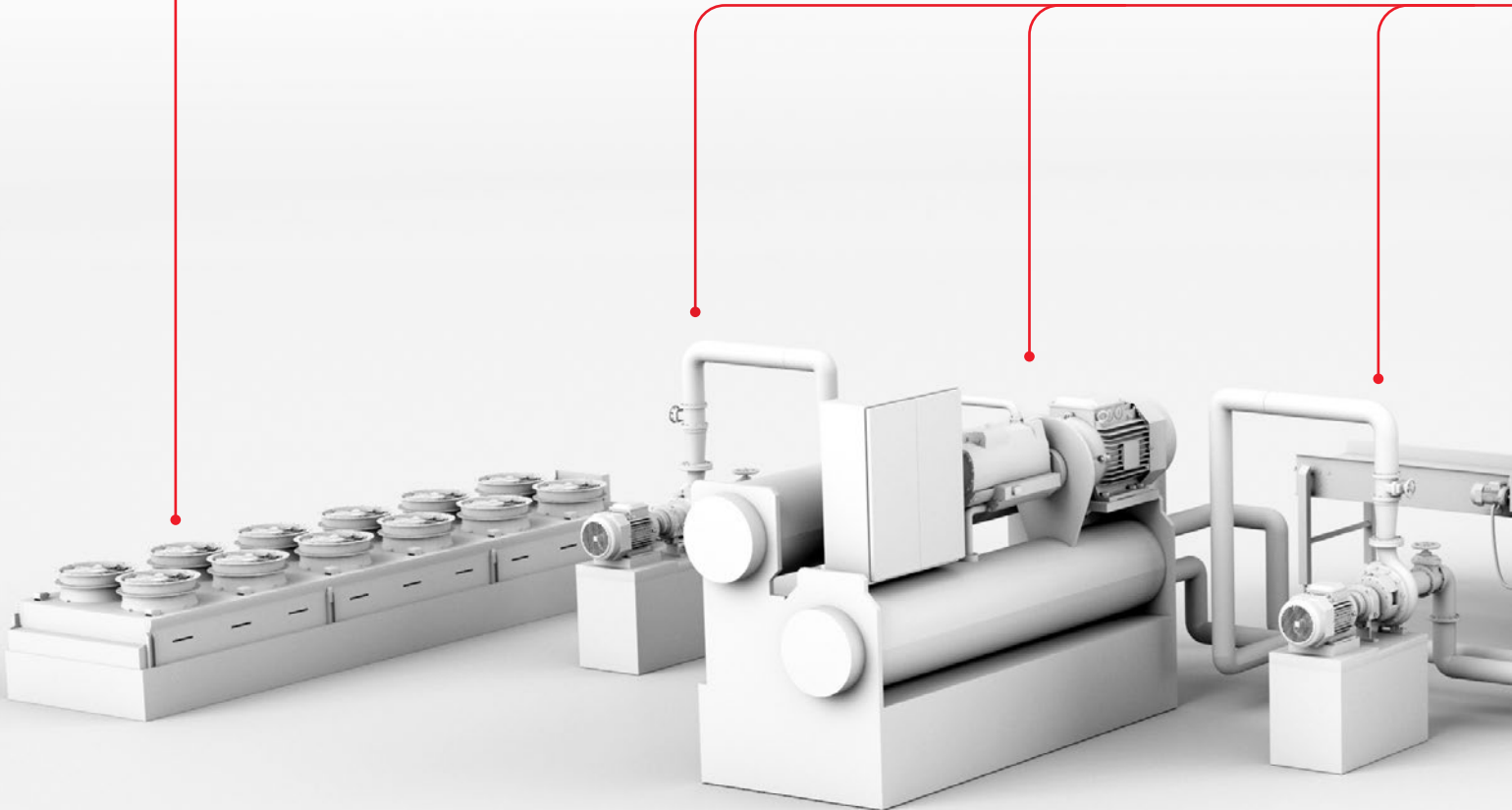

Pumps for condensers and evaporators

You can save energy compared to traditional throttling valves by controlling your pumps with variable speed drives. As well as saving energy, you will benefit from useful extra functions like:

- Return water temperature control
- De-icing control for water cooling tower
- Pre-heating to avoid damage during cold starts
- Belt and bearing maintenance notifications
- Reduction of mechanical stress and water hammer
- Anticavitation control detects cavitation and ensures optimal pump speed to avoid it
- Intelligent multi-pump control
- ABB Ability™ Smart Sensor for wireless remote monitoring and analytics of the pump motor

Compressors

ABB drives are suitable to run all kinds of compressor and motor types used for compressing ammonia or other refrigerants. Our ACS880 drives support high-speed compressor motors and our ACS580 drives include a dedicated firmware for refrigeration compressors. By using the drive's internal programmability, interlocks between different functions can be built according to process needs.



Cooling compressors in food and beverage

Food and beverage is by far the biggest category in industrial refrigeration installations. From baking to meat, dairy and fruit and vegetables to transporting them, the sector requires refrigeration throughout all stages of the cold chain.

Food and beverage software package for ACS580 (+N8057) Cooling compressor control

We utilize the best-in-class drive with a dedicated, purpose-built software for cooling compressors.

Built-in intelligence, including:

Cooling compressor software

Sets typical parameter values for cooling compressor application and makes it easier to commission the drive.

Multi compressor control

Controlling more than one compressor with one drive depending on the need, by changing all the relevant parameters and settings automatically.

Pressure to temperature conversion

Internal scaling to be done based on refrigerant. System then automatically adjusts the cooling by utilizing the PID.

Short cycle protection

Provides time delays in order to limit the number of starts to avoid damage from repetitive rapid-starting cycles.





Reliable

Our high-quality products prevent the risk of expensive unplanned downtime.

Package solution

ABB provides complete solutions, including drives, motors and PLCs, coupled with global domain expertise.

Energy efficiency

Using VSDs on cooling compressors will give an average energy savings of 20% compared to running in DOL mode.

Easy to use

User friendly interface brings you simplicity and saves your time.

Flexible

Supporting all major Fieldbus protocols, wide I/O capacity, Wall mounted frames up to 250 kW with cooling compressor software.

Scalable

Available in several different frame types with wide range of power, IP class and voltage options.

ABB drives and PLCs for compressor applications



ABB's programmable logic controllers (PLCs) and control panels

PLCs to control cooling compressor stations

Efficiency and performance are the result of accurate and advanced control. ABB supplies a full range of low voltage control products to safely start, protect and control compressors. The AC500, AC500-eCo, AC500-S and AC500-XC scalable PLC ranges provide solutions for small, medium and high-end applications.

- Our AC500 PLC platform offers different performance levels and is the ideal choice for high availability, extreme environments, condition monitoring, motion control or safety solutions.
- Our AC500 PLC platform offers interoperability and compatibility in hardware and software, from compact PLCs up to high-end and safety PLCs.

Control panels on the compressor door

The CP600-eCo, CP600 and CP600-Pro control panels offer a wide range of features and functionalities for maximum operability. ABB control panels are distinguished by their robustness and easy usability, providing all the relevant information from production plants and machines at a single touch.

Engineering suite

Automation Builder is an integrated software suite that connects the engineering tools for PLC, safety, control panels, SCADA, drives and motion. Automation Builder combines the tools required for configuring, programming, debugging and maintaining automation projects from one common intuitive interface.

For more information, visit new.abb.com/plc



All-compatible drives portfolio

The all-compatible drives share the same architecture, software platform, tools, user interfaces and options. Yet, there is an optimal drive for every operation, from the smallest water pump to the biggest cement kiln, and everything in between. For compressors, there is a wide variety of drives to match your needs.

When used with air compressors, the drives reduce energy consumption, air consumption and leakage, and provide improved pressure control. Refrigeration compressors used with drives can achieve high total efficiency, even at reduced load, and energy-efficient capacity control. In refrigeration screw compressors, smooth capacity control enables precise regulation of the refrigeration temperature.

Retrofitting of compressor stations

ABB drives can be used for retrofitting air and cooling compressors. If the existing compressor controller cannot be updated, then the ABB programming tools can help to add extra control functions in the compressor system. Also fieldbus communication interfaces can be customized to better match with the existing automation system. Direct torque control (DTC) or vector control provides adequate accuracy to run the compressor according to torque without PID pressure sensor feedback.

Brand labeling concept

ABB can provide brand labeling to make sure your drives match your brand's visual identity. The brand labeling concept includes for example the OEM's own logo on the drive's front panel and type plate. Also the control panel boot-up logo can be customized.

For more information, visit new.abb.com/drives

All-compatible drives for compressors

Benefits for your application

ABB all-compatible drives are suitable for many different compressor applications: stationary air compressors, cooling compressors, vacuum compressors, hermetic cooling compressors, and many more.

Feature	ACS380	ACS480	ACS580	ACS880
	Adaptable performance and flexibility for small power compressors	Effortless and efficient drive control for small power compressor applications	Effortless and efficient drive control for wide range of compressor applications	Flexibility and high performance for all compressor applications
All-compatible offering with wide voltage and power ranges	The all-compatible offering is suitable for all kind of industrial environments. Same user interface and connectivity tools can be used to connect drives in different sizes and enclosure classes for easy compressor integration. It also enables a quick learning curve to operate equipment because they all share the same software structure.			
1-phase, 200 - 240 V	0.25 - 2.2 kW	0.25 - 2.2 kW		
3-phase, 208 - 240 V	0.25 - 11 kW	0.25 - 11 kW	0.75 - 75 kW	0.75 - 75 kW
3-phase, 380 - 415 V	–	–	–	0.75 - 1,400 kW
3-phase, 380 - 480 V (ACS880 up to 500 V)	0.25 - 22 kW	0.55 - 22 kW	0.75 - 500 kW	0.75 - 1,600 kW
3-phase, 525 - 690 V	–	–	–	5.5 - 6,000 kW
Mounting options	ABB drives offering covers several different mounting methods. From this wide offering, it's possible to select the right drive for the right place.			
Enclosure	Drive module (IP20)	Drive module (IP20)	Wall-mounted (IP21 or IP55) Drive module (IP00 or IP20) Cabinet-built (IP21, IP42 or IP54)	Wall-mounted (IP21 or IP55) Drive module (IP00 or IP20) Cabinet-built (IP22, IP42 or IP54)
Side-by-side mounting	x	x	x	x
Flange mounting	–	–	x (up to 250 kW)	x (up to 630 kW)
Horizontal mounting	x	x	x	x
Marine certifications available	–	–	–	Marine type approval + possibility for product certification
Firmware and programmability	The basic drive features fulfil the standard compressor requirements, and if more sophisticated functions are needed, adaptive programming and IEC-61131-1-3 programming tools can be used for seamless drive integration with existing and new systems.			
Basic compressor control features	x	x	x	x
Cooling and refrigeration compressor license	–	–	x	
Stall protection	x	x	x	x
Configurable functions to supervise pressure and temperature	x	x	x	x
Motor temperature monitoring	x	x	x	x
Different parameter access levels	x	x	x	x
Direct PTC/Pt100 sensor connectivity	x	x	x	x
Flying start to catch the rotating motor	x	x	x	x
Adaptive programming	x	x	x	x
Motor preheating	x	x	x	x
IEC61131-1-3 programming	–	–	–	x
PFC for multicompressors	PFC control guarantees wider air volume supply by switching on and off parallel compressor stations based on the need.			
PFC	–	x	x	–
Primary setting menu for easy commissioning for PFC multicompressors	–	x	x	–

Feature	ACS380	ACS480	ACS580	ACS880
	Adaptable performance and flexibility for small power compressors	Effortless and efficient drive control for small power compressor applications	Effortless and efficient drive control for wide range of compressor applications	Flexibility and high performance for all compressor applications
Energy efficiency	These features reduce the operation cost by enabling the optimized consumption as well as improved energy efficiency.			
Real-time clock to optimize energy consumption	x (if external assistant panel is used)	x	x	x
EnergySave calculator tool	x	x	x	x
PID sleep mode when not in use	x	x	x	x
Support for IE5-class motors	x	x	x	x
Support for IM, SynRM and PM motors	x	x	x	x
Regenerative support	–	–	–	x
Low harmonic support	–	–	–	x
Common DC	x	–	–	x
Energy optimizer	–	x	x	x
Swinging choke	–	–	x	–
Monitoring and maintenance	With the help of these features the users can, for example, prevent overdimensioning of the drive, see if any abnormal situations have occurred, identify the need for preventive maintenance, and easily track faults as well as perform troubleshooting.			
Maintenance counter	x	x	x	x
Load curve statistics	x	x	x	x
Fault logger	x	x	x	x
EnergySave calculator	x	x	x	x
Support for different languages	13 languages with an external assistant control panel	21 languages	21 languages	15 languages
Motor speed/frequency control	Advanced motor control enables high starting torque and thus minimizes the need for overdimensioning the motor. This further reduces the investment cost as smaller motor can be used. In addition, hexagonal flux control mode reduces the heat losses, leading to higher efficiency.			
Scalar and vector control support	x	x	x	–
Scalar and direct torque control (DTC) support	–	–	–	x
Hexagonal flux control mode	–	x	x	x
Advanced high-speed motor control	–	–	–	x
Safety	Built-in STO in drives together with additional safety functions enhance application safety, and the ATEX-certified PTC thermistor guarantees safe motor temperatures even in a potentially explosive environment.			
STO function	x	x	x	x
Safe stopping over PROFIsafe with FSPS-21	x	–	x	x
Advanced functional safety	–	–	–	x
ATEX-certified PTC thermistor connection	–	x	x	x
Shell ATEX-approved	–	–	–	x
Customization	ABB all-compatible drives support flexible customization to support brand recognition and user experience.			
Brand labeling	x	x	x	x
Customized parameter macros	x	x	x	x

Program your drive with ABB tools

Application programming

Adaptive programming

Adaptive programming is a common application programming tool for the ABB all-compatible drives. It is offered as default in the ABB all-compatible drives without licensing. This world-class programming interface takes easy drive adaptation to a higher level. The combination of function and sequence blocks enables good flexibility without adding complexity. Adaptive programming offers an easy alternative for simple programming needs.

IEC programming

ABB ACS880 industrial drives can be ordered with the application programming functionality. It allows you to add your own program code to the drive using the ABB Automation Builder programming tool. The programming method and languages are based on the IEC 61131-3 programming standard. ABB Automation Builder is also used for configuring and programming the ABB AC500 PLC family of devices.

With the drive application programming, you can create application-specific features on top of the drive firmware functionality. You can utilize the standard and extension I/O and communication interfaces of the drive along with the appropriate firmware signals. Your program is executed in parallel with the drive control tasks using the same hardware resources.

In addition, you can create your own parameters and events (faults and warnings) that are visible on the ACS-AP-x control panel and in the Drive composer pro/entry commissioning tools.

Tools

- 3AUA0000108087, Drive composer pro DCPT-01, single workstation license
- 3AUA0000145150, Drive composer pro DCPT-01, for 10 workstations
- 3AUA0000145151, Drive composer pro DCPT-01, for 20 workstations
- 3AUA0000108087, Drive composer entry DCET-01, free download from ABB website
- Automation Builder, for drive IEC programming
- Free 61131-3 engineering for simple PLC solutions

Customization and easy re-configuration

ABB also provides tools to customize the drive user interface and to load all software content efficiently into the drives.

For loading the software content into the drives, ABB offers efficient tools for all all-compatible drives. The memory unit copy station is used to efficiently copy software packages to multiple memory units for industrial drives. CCA-01 is used to load software packages into standard and industry-specific drives without a mains supply.

Tools

- 3AXD50000015936, Drive Customizer PC tool DCZT-01
- 3AUA0000131054, ZMU copy station ZMP-01 kit
- 3AXD50000019865, configuration adapter CCA-01

Adaptive programming example

Solution for compressors

An adaptive program example for a compressor designed by ABB experts provides an easy solution for typical compressor applications.

The example can be used as a template for compressor-specific control or fine-tuning compressor operation without external components in new and retrofit installations.

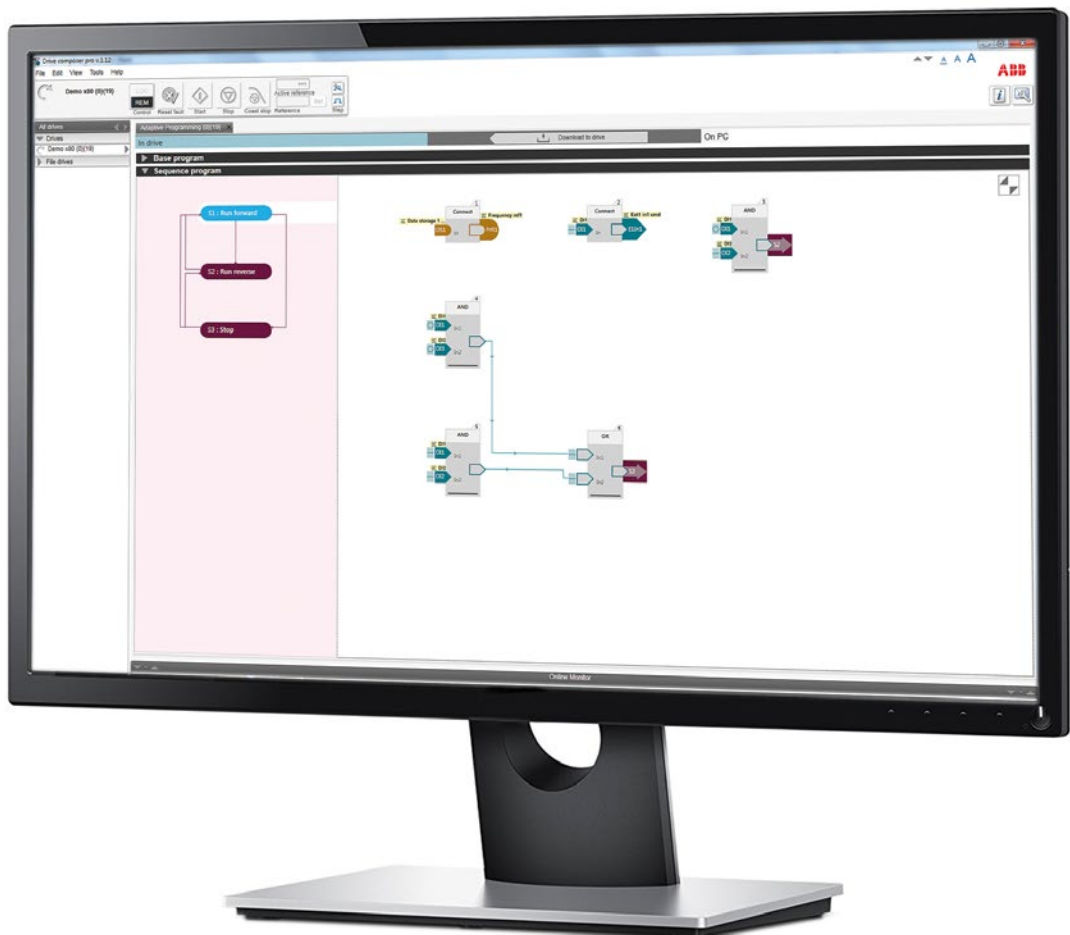

Best motor control and highest energy efficiency

Our drives can control any type of AC motor for compressors, including induction, permanent magnet and synchronous reluctance motors.

All ABB drives control, run and support the main types of electric motors in compressor applications, including traditional induction motors, permanent magnet motors and, most recently, the most energy-efficient and compact motor generation – SynRM.

As compressor manufacturers are increasingly asking for packaged solutions, ABB's dedicated OEM motor team can propose and provide motor-drive combinations where detailed and committed focus is on a matched, ready-made and optimized, single-source motor-drive solution.

ABB's motor-drive package design, selection and commercialization process always considers and concentrates on the compressor manufacturer's desired needs, whether it is for serial or engineered compressor manufacturing.

ABB drives can offer significant benefits to compressor manufacturers:

- Motor duty cycles, permissible motor temperature rise and insulation class with variable speed drives
- Continuous and short-time motor speed and torque capacity, thermal protection and motor-drive package energy efficiency, among other issues

Synchronous reluctance motors

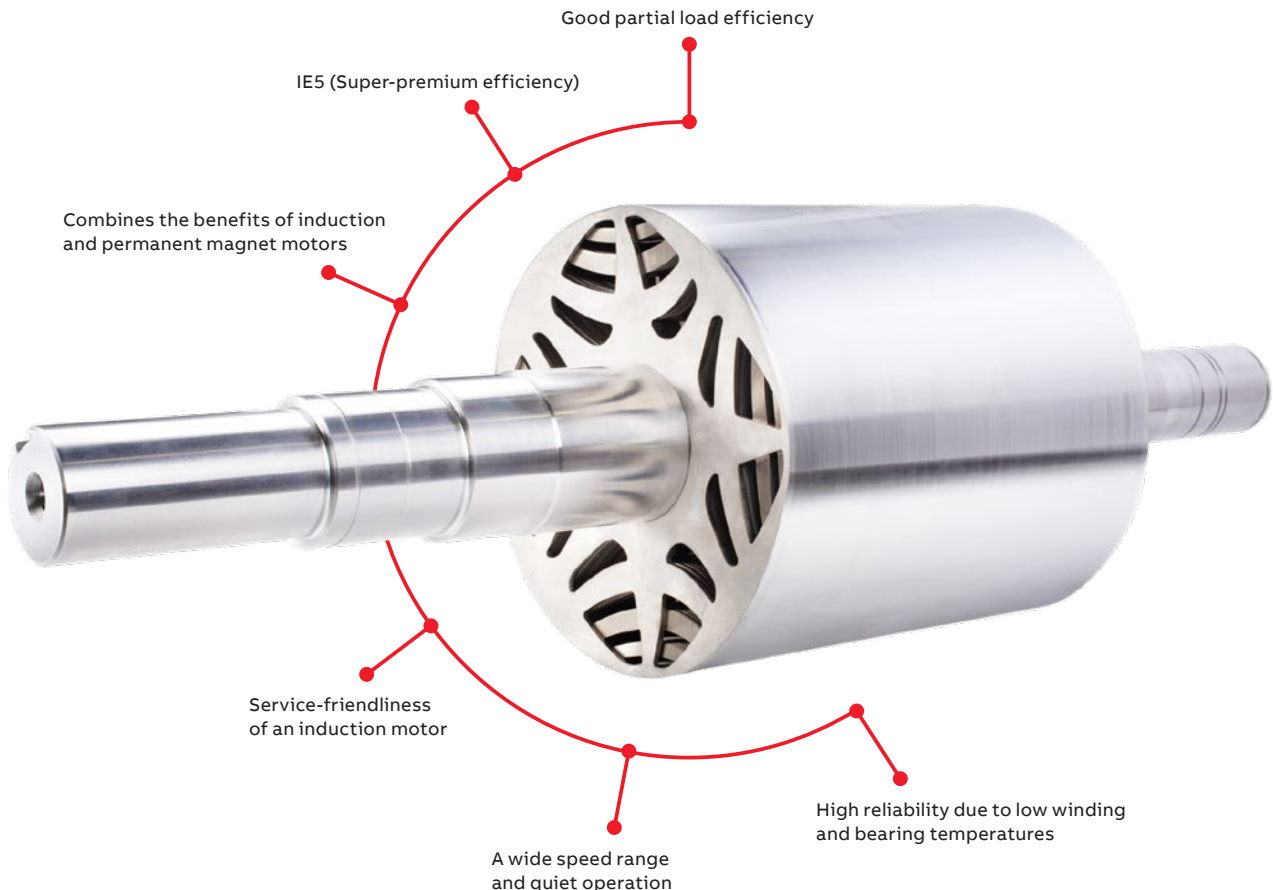

Wide range of motors for different types of compressors

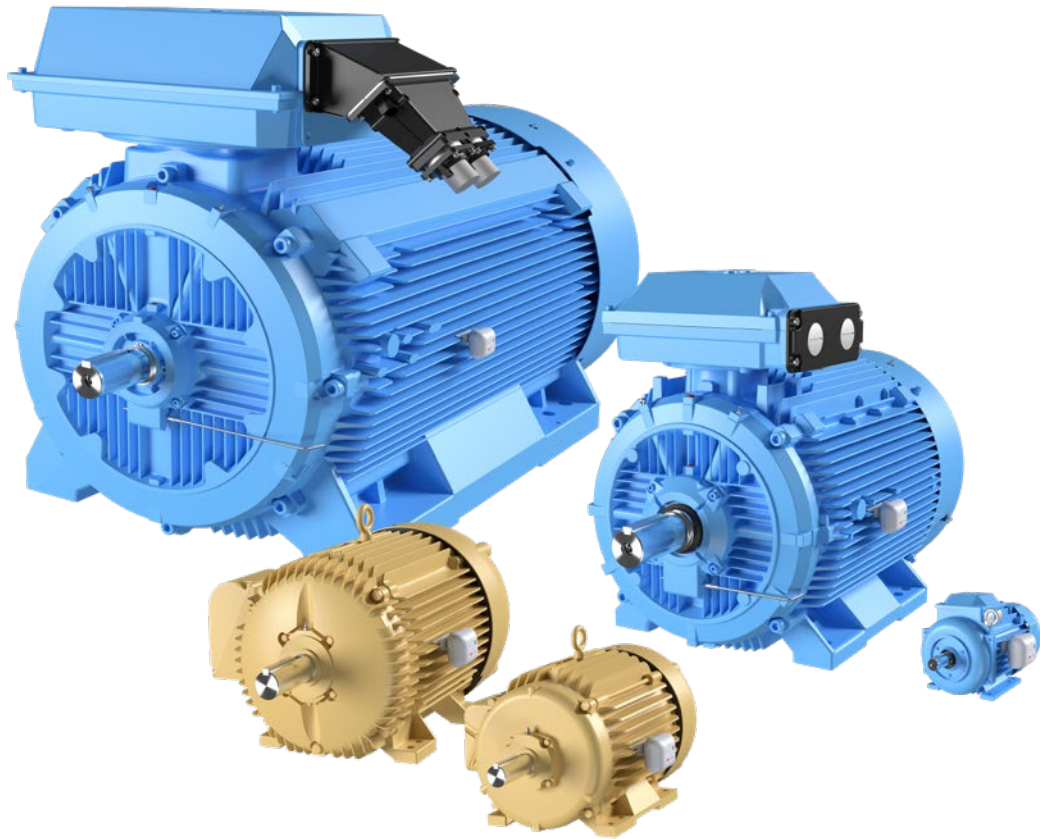

ABB's synchronous reluctance motors

ABB's SynRM packages combine benefits both from ABB motors and drives and enable manufacturers to utilize extremely high efficient drive gear in all kinds of compressors. All in all SynRM means Super Premium efficiency also under partial loads, at low motor running temperatures, precise vibration-free synchronous speed control, reduction in motor size and lower audible motor noise. Verified package statements for SynRM packages help compressor manufacturers to design the very lowest energy consumption for the compressor installation.

ABB's IEC motors

ABB's IEC low voltage motors are suitable for all compressor applications fulfilling all national and international mandatory efficiency and MEPS (Minimum Energy Performance Standard) regulations. Basically, ABB offers two types of standard IEC induction motors: process

performance and general performance motors. Several properties set ABB's process performance motors apart: their efficiency, use of leading-edge technology and virtually limitless options they provide for customization. On the other hand, ABB's general performance motors suit and meet all the basic requirements of most compressor manufacturers with rapid order-to-stock delivery times.

ABB's NEMA motors

ABB's NEMA motors offer the broadest line of energy-efficient motors to meet any application need that compressor manufacturers may have. Designed and built with a focus on reliability and lowest total cost of ownership, these flagship ABB motors meet – and even exceed – all NEMA energy efficiency levels. ABB's NEMA motors are available throughout North America from regional stockists or can be manufactured to fit the most specific compressor application needs in the harshest environments.

Our service expertise, your advantage

ABB Motion Services helps customers around the globe by maximizing uptime, extending product life cycle, and enhancing the performance and energy efficiency of electrical motion solutions. We enable innovation and success through digitalization by securely connecting and monitoring our customers' motors and drives, increasing operational uptime, and improving efficiency. We make the difference for our customers and partners every day by keeping their operations running profitably, safely and reliably.

With a service offering tailored to your needs, ABB Motion Services maximizes the uptime and extends the life cycle of your electrical motion solutions, while optimizing their performance and maximizing your energy efficiency gains throughout the entire lifetime of your applications. We help to keep your applications turning profitably, safely and reliably.

Digitalization enables new smart and secure ways to prevent unexpected downtime while optimizing the operation and maintenance of your assets. We securely connect and monitor your motors, drives or your entire powertrain via our easy-to-use cloud service solutions. Connecting your applications also gives you access to our in-depth service domain expertise.

We quickly respond to your service needs. Together with our partners, local field service experts, and service workshop networks, we provide and install original spare parts to help resolve any issues and minimize the impact of unexpected disruptions.

Our tailored to your needs service offerings and digital solutions will enable you to unlock new possibilities. Not only are we your premier supplier of motion equipment, we are your trusted partner and advisor offering support throughout the entire life cycle of your assets. We ensure your operations run profitably, safely and reliably and continue to drive real world results, now and in the future. Our service teams work with you, delivering the expertise needed to keep your world turning while saving energy every day.



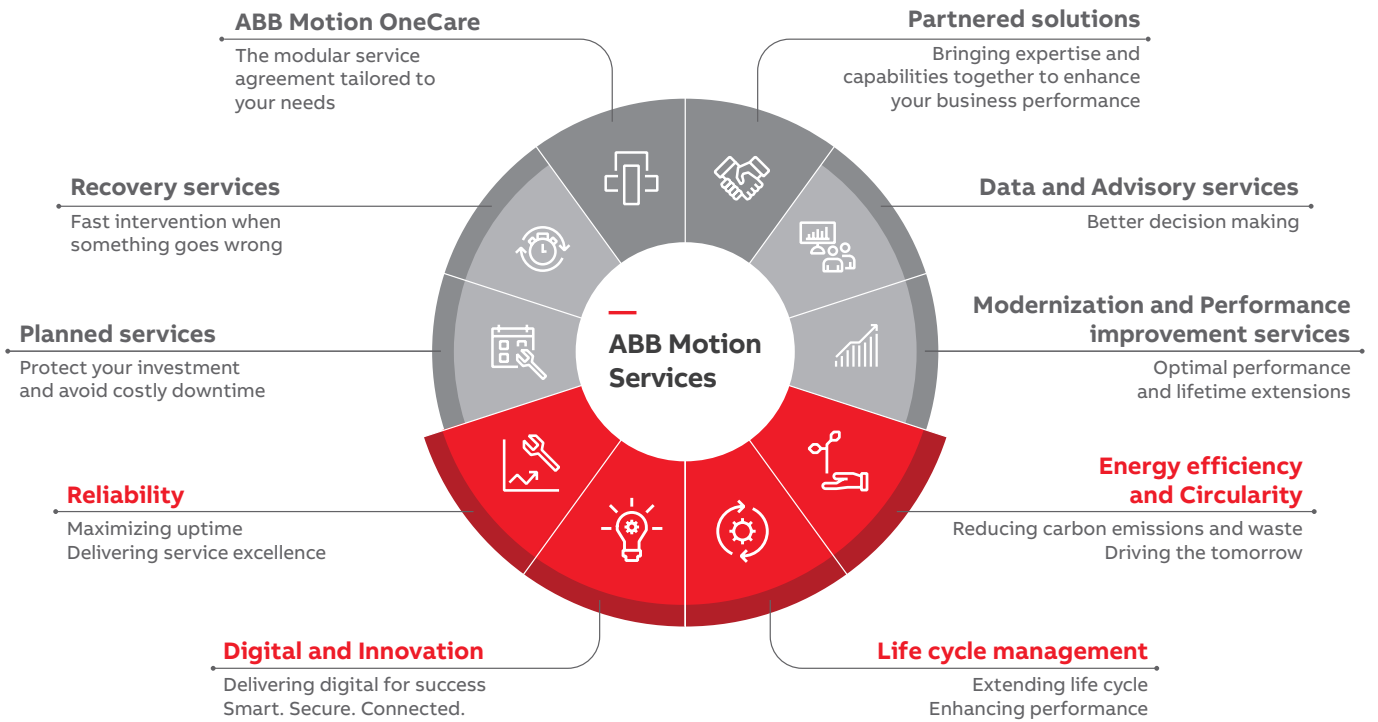

OUR EXPERTISE
YOUR ADVANTAGE



ABB drives life cycle management

A life time of peak performance

You're in control of every life cycle phase of your drives. At the heart of drive services is a four-phase product life cycle management model. This model defines the services recommended and available throughout drives' lifespan.

Now it's easy for you to see the exact service and maintenance available for your drives.

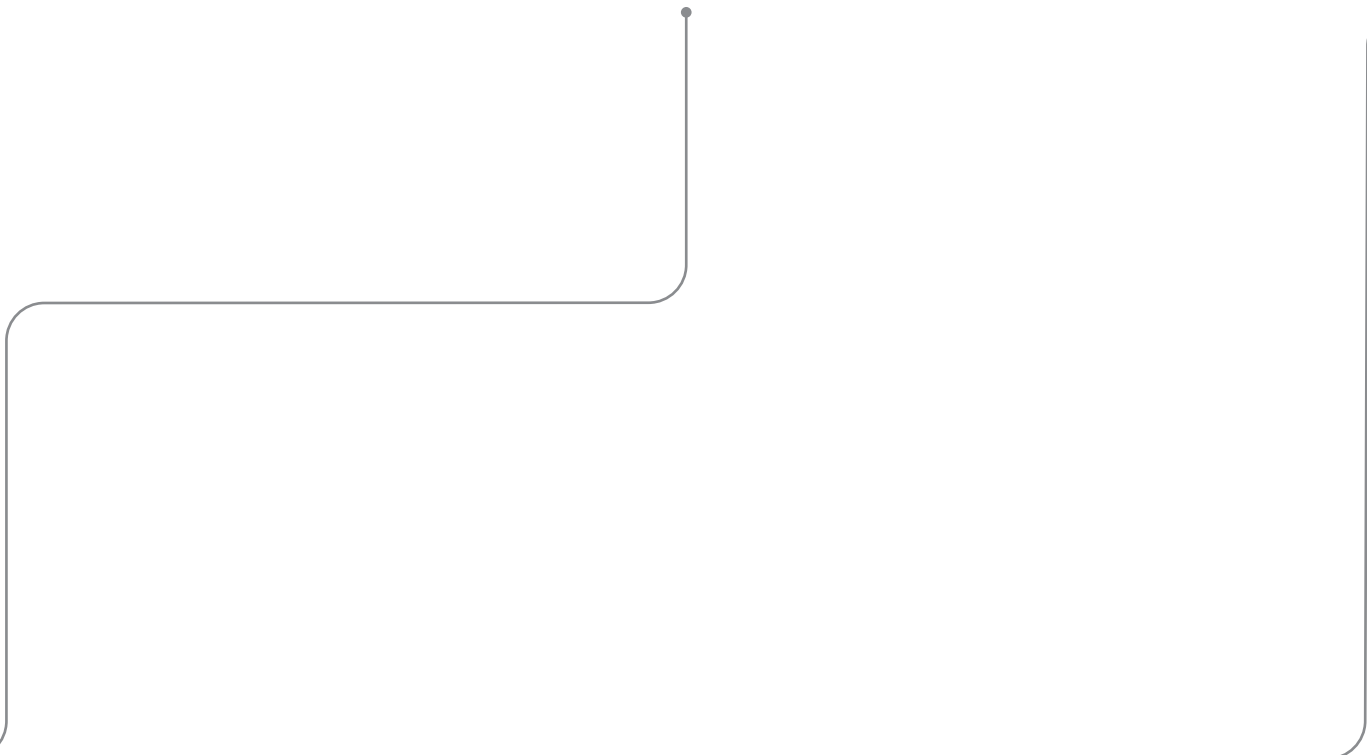
ABB drives life cycle phases

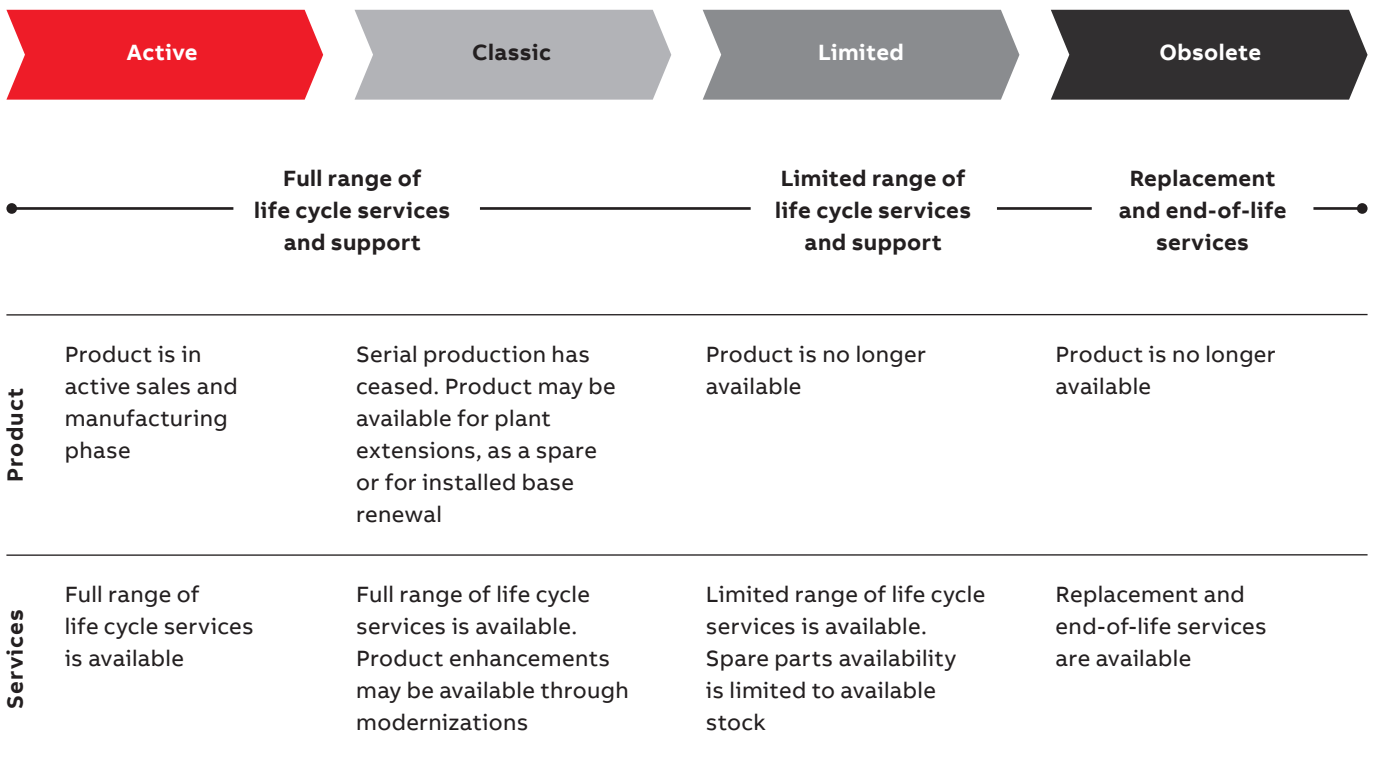



Keeping you informed throughout the life cycle

We notify you every step of the way using life cycle status statements and announcements.

Your benefit is clear information about your drives' status and precise services available. It helps you plan the preferred service actions ahead of time and make sure that continuous support is always available.

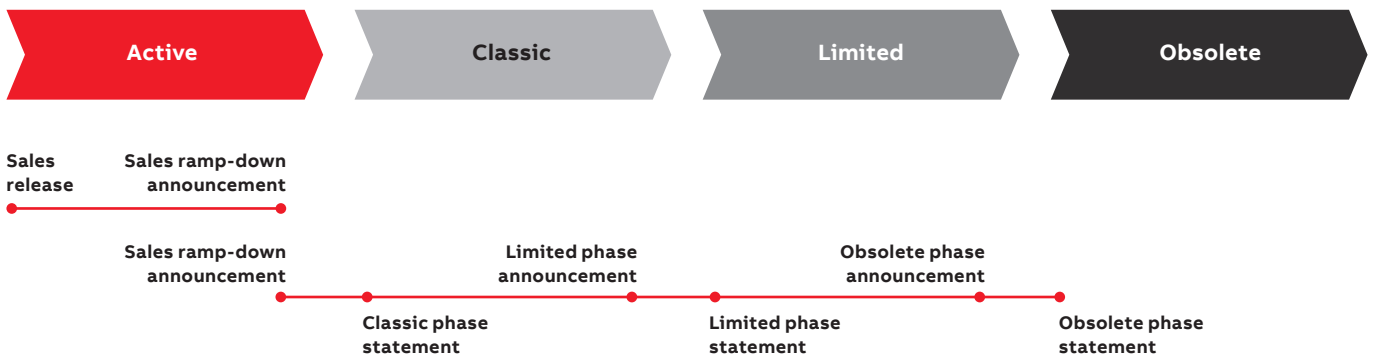

Sales release

Details about product portfolio and release schedule.

Sales ramp down announcement

Last time to buy, and last delivery dates, informed well in advance.

Life cycle phase change announcement

Early information about the upcoming life cycle phase change and impact on the service availability. Informed well in advance, minimum six months prior to the change.

Life cycle phase statement

Information about the current life cycle status, product and services availability and recommended actions. Plan for the next life cycle phase transition.

Additional information

We reserve the right to make technical changes or modify the contents of this document without prior notice. With regard to purchase orders, the agreed particulars shall prevail. ABB does not accept any responsibility whatsoever for potential errors or possible lack of information in this document.

We reserve all rights in this document and in the subject matter and illustrations contained therein. Any reproduction, disclosure to third parties or utilization of its contents – in whole or in parts – is forbidden without prior written consent of ABB.



—
For more information, please contact
your local ABB representative or visit

new.abb.com/drives
new.abb.com/motors-generators
new.abb.com/drives/drivespartners
new.abb.com/plc